



MAGNUM WET-PRIME DIESEL TRASH PUMP



ADVANCED FEATURES:

- EXTERNAL ADJUSTABLE WEAR PLATES
- STAINLESS STEEL SHAFT
- DUCTILE IRON - VOLUTE AND IMPELLER
- FUEL CAPACITY - 110 GALLONS (MINIMUM 24 HOURS RUN TIME)

The Magnum Wet-Prime Diesel Trash Pump is maneuverable and portable, designed and built for the most demanding environments. The wet-priming centrifugal pump is capable of handling 3 inch diameter solids and flow capacities up to 1550 GPM. These models also offer a 110 gallon fuel capacity for more than 24 hours run time. The trailer is easily detachable, allowing for skid configurations for a variety of applications. Our unparalleled customer service/technical support teams and heavy-duty equipment is what gives our customers the ultimate "return on investment."

Features

- Wet-priming centrifugal pump – 4" and 6"
- Flows up to 800 GPM/4", 1550 GPM/6"
- Heads up to 145' TDH/4", 135' TDH/6"
- Electric start
- 110 gallon fuel tank with gauge
- ¼" wall fuel tank
- Analog gauge control panel with safety shutdowns
- Remote input start/stop controls – standard
- Removable cover plate
- Shaft material – 17-4 PH stainless steel
- Pressure relief valve – brass
- O-rings – viton standard
- Clean out cover – easily removable
- Central lift point – standard
- Fuel transfer pump for extended run times – optional
- Bauer-type fittings – optional
- Other fittings available upon request
- Trailer – standard/easily detachable
- 2" ball hitch – standard
- 3" lunette ring for pintle hitch – optional
- Front and (2) rear stabilizing jacks
- Surge brakes – standard
- Electric brakes – optional
- Heavy duty 5000 lb. axle and wheels – standard
- Heavy duty truck tie downs
- Warranty – one year unlimited hours, two years 2000 hours

For more information:

Call: 1-800-926-9768 Fax: 920-361-2214 Or visit: www.M-P-LLC.com

EMPOWERING REAL PEOPLE

215 POWER DRIVE BERLIN, WISCONSIN 54923-2420
™ TRADEMARK AND ® REGISTERED TRADEMARK OF MAGNUM PRODUCTS LLC



SPECIFICATIONS

Engine:	John Deere – 4"/4024TF – 56 HP (continuous) 66 HP (intermittent) John Deere – 6"/5030TF – 64 HP (continuous) 75 HP (intermittent)
Pump:	Wet-Priming Centrifugal Pump – 4" and 6"
Max Solid Size:	3"
Impeller:	Open type two-vane impeller handles 3" solids ASTM A536 grade 65-42-12 ductile iron material
Wear Plate:	Removable steel plate with stainless hardware – externally adjustable
Mechanical Seal:	Single seal with silicon carbide seal faces, viton elastomers, stainless hardware and spring
Bearing Housing:	ASTM A48 Class 30 gray iron and oil lubricated with sight gauge and lip seal to isolate seal oil from bearing housing

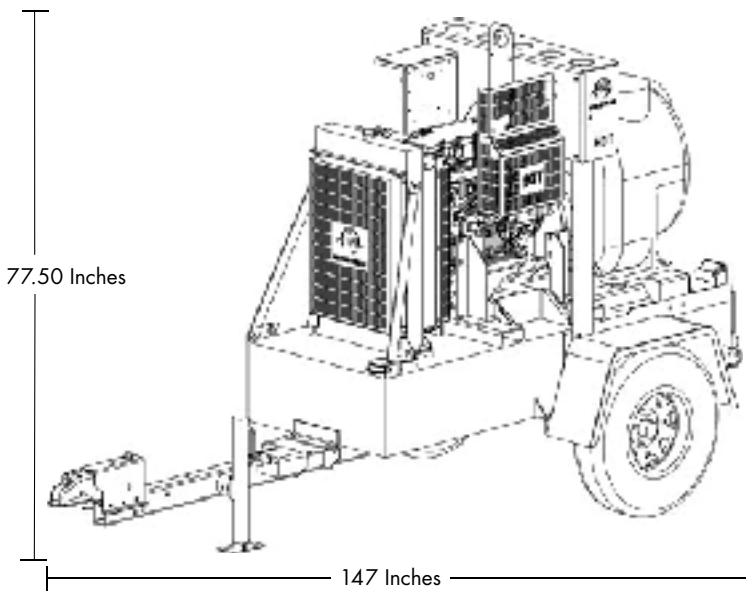

MTP 4000S Performance Curve

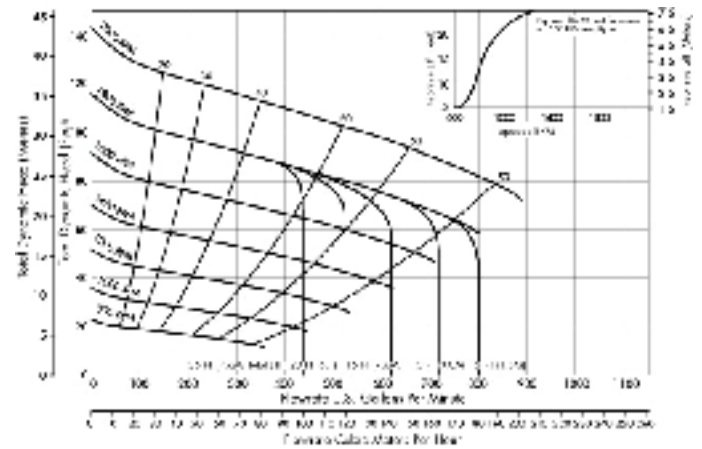

MTP 6000S Performance Curve

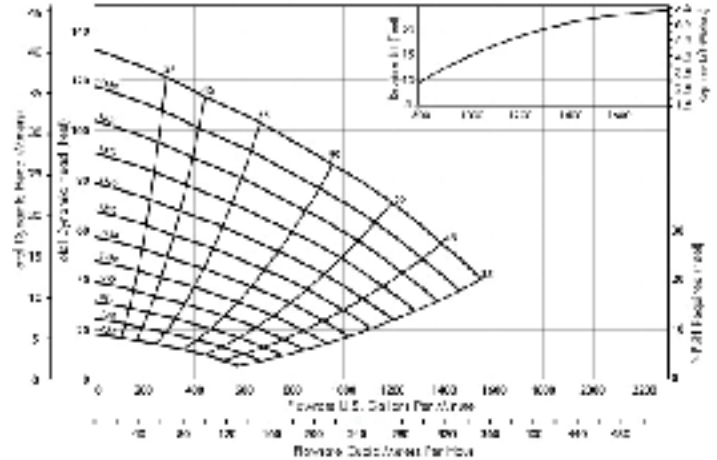

For more information:

Call: 1-800-926-9768 Fax: 920-361-2214 Or visit: www.M-P-LLC.com

SPECIFICATIONS SUBJECT TO CHANGE
CONTACT YOUR REPRESENTATIVE FOR DETAILS

